



Cloud Cap Technology Systems Software Update Guide

September 28, 2011

Author:
Doug Miley

2621 Wasco Street / PO Box 1500 / Hood River, OR 97031

(541) 387-2120 phone / (541) 387-2030 fax

www.cloudcaptech.com / sales@cloudcaptech.com / support@cloudcaptech.com

The Goodrich logo consists of the word "GOODRICH" in a bold, dark blue, sans-serif font. Above the letters "I", "D", and "R" are three red, horizontal, slanted brushstrokes that sweep from left to right, creating a sense of motion or speed.

GOODRICH

Cloud Cap Technology, a Goodrich Company

Table of Contents

1	Introduction.....	3
1.1	Items Needed	3
2	Hardware Connection Diagrams.....	4
2.1	Gimbals.....	4
2.2	Piccolo Autopilot	4
2.3	Desktop Ground Station.....	5
2.4	Portable Ground Station (PGS).....	5
3	Saving the Piccolo Autopilot Parameters	6
4	Updating the System Software.....	6
5	Updating the Firmware	7
5.1	Firmware Versions.....	7
5.1.1	Satellite Based Augmentation System (SBAS)	8
5.2	Firmware Update Procedure	8
5.2.1	Option 1: Automatic Programming	8
5.2.2	Option 2: Manual Programming.....	9
5.3	Troubleshooting	10

1 Introduction

This guide covers how to update Cloud Cap Technology products with the latest software and firmware. The software and firmware should be updated when new versions are released. Since the hardware and software work in sync with one another, they should be updated at the same time with the latest release.

Software and firmware are available from the Downloads page at www.cloudcaptech.com.

1.1 Items Needed

- **Programming serial cable:** Included in the Developers Kit. Used for updating the Piccolo, TASE Gimbal, and the Desktop Ground Station firmware (**Figure 1**).
- **Gimbal programming cable:** Included in the Gimbal Developers Kit. Interfaces between the TASE gimbal and programming serial cable (**Figure 2**).
- **9-Pin standard serial cable:** Included in the Portable Ground Station Kit. Used for updating the Portable Ground Station firmware (**Figure 3**).
- **Piccolo interface cable with 6-pin MTE connector:** Included in the Developers Kit. Provides multiple connections including PC and autopilot power (**Figure 4**).
- **PC with a serial port:** A standard PC with a serial port will suffice. If using a laptop, a serial port adapter may be required. CCT recommends the PA088U USB-Serial adapter from Targus.



Figure 1 - Programming Serial Cable



Figure 2 - Gimbal Programming Cable



Figure 3 - 9-Pin Standard Serial Cable



Figure 4 - Piccolo Interface Cable

2 Hardware Connection Diagrams

2.1 Gimbals

The gimbal programming cable plugs in to the auxiliary interface connector on the gimbal and the 6-pin MTE connector of the Piccolo programming cable. The PC serial connector on the primary gimbal interface cable should be disconnected from the PC during programming.



CAUTION! Do not connect the programming cable during normal gimbal operation.

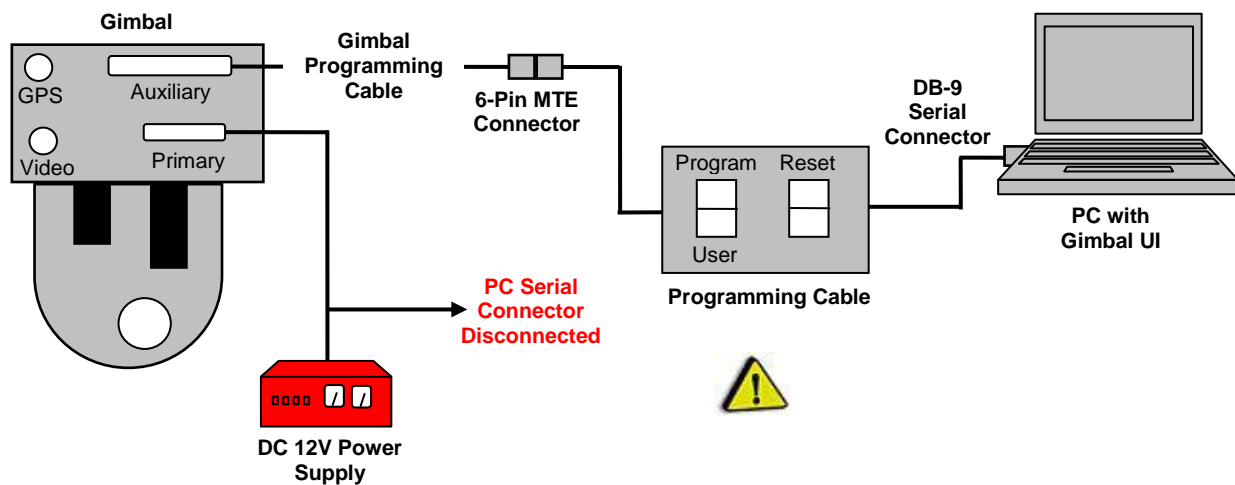

Figure 5 - Gimbal Programming Connection Diagram

2.2 Piccolo Autopilot

Connect the programming cable to the 6-pin MTE connector on the Piccolo interface cable. Connect the DB-9 serial connector of the programming cable to the PC serial port.

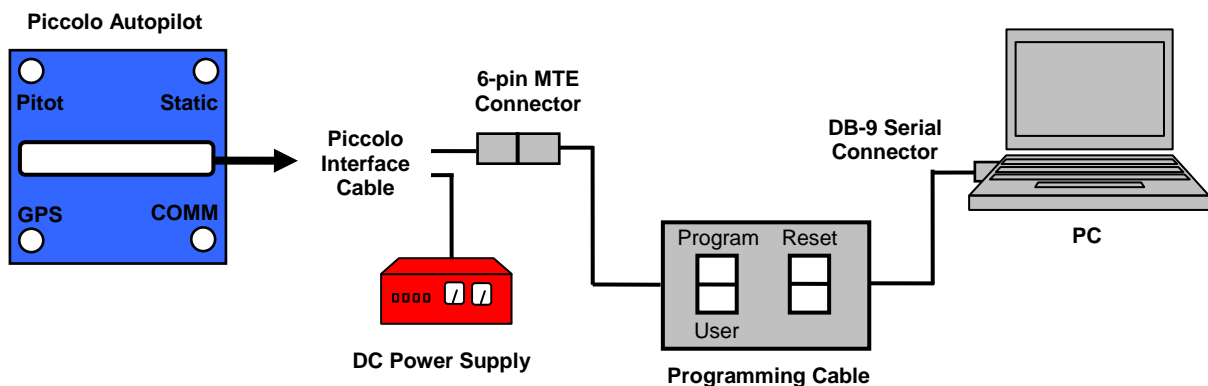

Figure 6 - Piccolo Autopilot Programming Connection Diagram

2.3 Desktop Ground Station

Connect the 6-pin MTE connector on the programming cable to the **Program Port** of the Desktop Ground Station. Connect the DB-9 serial connector of the programming cable to the PC serial port.

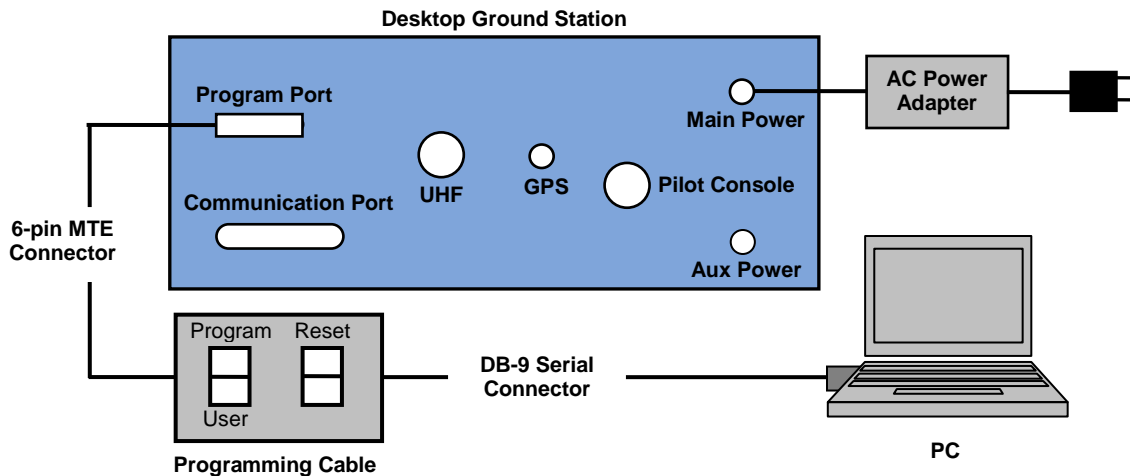

Figure 7 - Desktop Ground Station Programming Connection Diagram

2.4 Portable Ground Station (PGS)

Connect the 9-pin serial cable to the PC serial port and the **Link 2 Config** serial port of the PGS. The PGS has built in programming hardware so there is no need to use the programming cable.

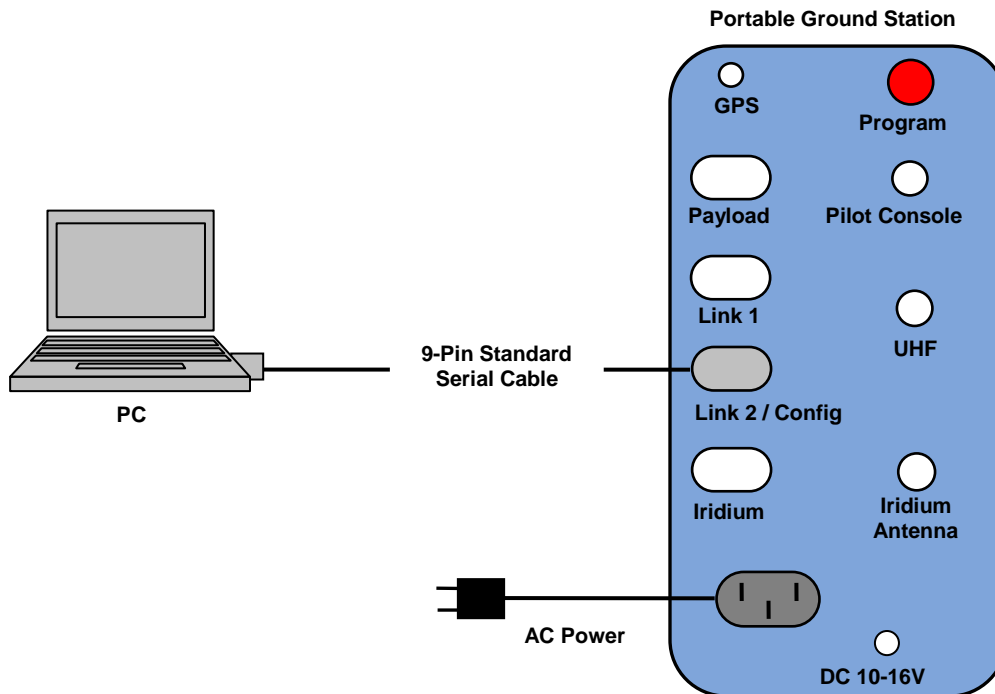

Figure 8 - PGS Programming Connection Diagram

3 Saving the Piccolo Autopilot Parameters

Before updating the Piccolo autopilot, as a precautionary measure, it is recommended to save all the current autopilot parameters.

When upgrading firmware (older version to a newer version) the new firmware may convert the parameters stored in the autopilot from the old format to the new format. If you are loading an older version of firmware, the parameters stored in the autopilot may be set to their default values by the old software. In this case you must use the saved parameters to restore the autopilot settings.

You can save the autopilot parameters over your established wireless comms link, or you can direct connect to the Piccolo using the programming cable.

1. Start the Piccolo Command Center. Power up the Piccolo.
2. Verify that you are you are communicating with the Piccolo.

*Note: If you using the program cable and are not communicating with the Piccolo, set the Programming cable to **Program**. Wait at least 60 seconds for the PCC to communicate with the Piccolo. Set the programming cable back to **User**.*

3. From the main PCC menu, go to **Window » Preflight Windows » Preflight**
4. In the **Preflight** window, click the **Save all** button. Name and save the XML file to a convenient directory. Do this for each autopilot that you are updating.

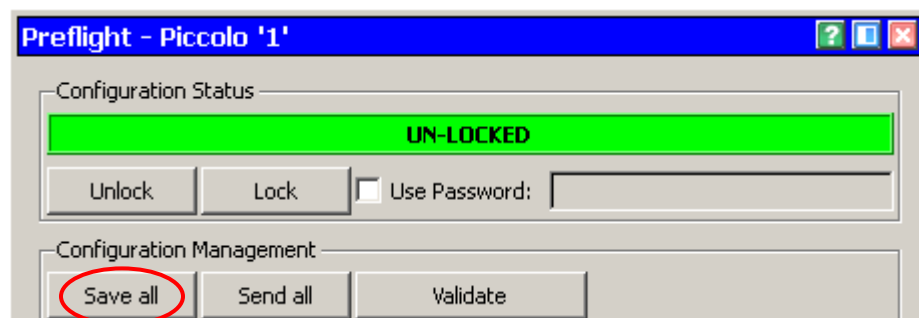

Figure 9 - Preflight Window

4 Updating the System Software

Use **Table 1** to select the appropriate installer file for the software you are updating. The installer files are available in the latest software release available on the Downloads page at www.cloudcaptech.com.

1. Open the appropriate installer file on your PC.
2. If you have previously installed the software, the installer will ask you to repair or remove the software. Select **Repair** and continue. If you have never installed software, the installer will guide you through the installation process.

Table 1 - Installer Table

Software Name	Installer File
Piccolo Command Center – 2.x	PccInstaller.msi
Piccolo System Software – 2.x	PiccoloInstaller.msi
Operator Interface (OI) – 1.x	OperatorInterfaceSetup.msi
Gimbal UI – 1.x	GimbalUI.msi
Gimbal System Software - 1.x - 2.x	GimbalInstaller.msi
ViewPoint - 2.x	ViewPointInstaller.msi

Check the [Cloud Cap Technology](http://www.cloudcaptech.com) website periodically for the latest software and firmware updates. [Join our list](#) if you would like to be notified of the latest product and software updates.

5 Updating the Firmware

Before updating the firmware on your CCT hardware systems, it is recommended to run the latest Piccolo and/or Gimbal system software installer(s). Along with updating the system software on your PC, it also installs the latest firmware files that you will use to update the Piccolo and/or Gimbal system hardware.

Updating the firmware consists of the following steps:

1. Connecting the hardware.
2. Placing the hardware in program mode.
3. Selecting the appropriate firmware.
4. Uploading the firmware to the hardware.
5. Resetting the hardware.

5.1 Firmware Versions

The table below matches the hardware with the firmware version and firmware file. The firmware files are available in the latest software release from the Downloads page at www.cloudcaptech.com.

Table 2 - Firmware Table

Firmware	Hardware	Firmware Versions	Notes
PiccoloFWG2.mot PiccoloHeliNet.mot PiccoloFWG3.mot	Piccolo Plus, Piccolo II, Piccolo LT, Piccolo SL	2.0.x - 2.1.1.x	<ul style="list-style-type: none"> • Helicopter firmware only available with v2.1.0.x » software • Piccolo SL must use v2.1.1.x » software.
GroundStation.mot GroundStation_NoSBAS.mot	Portable Ground Station, Desktop Ground Station	2.x	
GimbalLTflash.mot Gimbalflash.mot GimbalT2flash.mot	TASE LT/ TASE/TASE Duo/T2 Gimbals	1.x - 2.x	

5.1.1 Satellite Based Augmentation System (SBAS)

The Satellite Based Augmentation System (SBAS) uses geostationary satellites that broadcast corrections for a wide area. They rely on ground based systems that measure reference data. This data is compiled and uploaded to the SBAS satellites by SBAS satellite operators, then broadcast to GPS receivers. The corrections are similar to DGPS but are not as high performance. WAAS is the SBAS system in the United States. With WAAS corrections functional it is possible to attain +/-3m horizontal accuracy (one standard deviation), compared to approximately +/-5m horizontal with standard GPS. The **NoSBAS** firmware option disables the SBAS. This may be useful when operating in areas where SBAS is available but is not reliable.

5.2 Firmware Update Procedure

5.2.1 Option 1: Automatic Programming

1. Connect the hardware as shown in section 2 *Hardware Connection Diagrams*.
2. Power up the hardware.
3. Placing the Hardware in Program mode:
 - Set the **Program/User** rocker switch on the programming cable to **Program**. Firmly press the **Reset** switch to cycle the power off, and then back on.
 - For the Portable Ground Station first make sure the unit is off. Press and hold the **Program** button while simultaneously pressing the **Power** button.
4. Select the Firmware Programmer:
 - For Piccolo systems, go to the **Start** menu on your computer, **Cloud Cap Piccolo » Tools » Firmware Programmer**.
 - For Gimbal Systems, go to go to the **Start** menu on your computer, **Cloud Cap TASE » Tools » Firmware Programmer**.
5. Select the **Firmware Programmer** option from the list shown in **Figure 10**. This opens the **Firmware Programmer** application and automatically starts the programming process.

Piccolo System Firmware Options

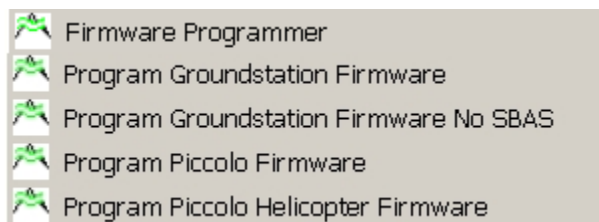

TASE Gimbal Firmware Options

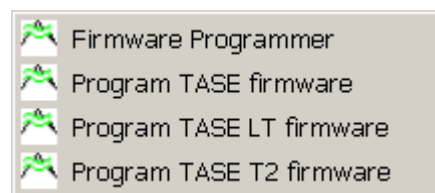

Figure 10 - Firmware Programmer Options

6. Reset the Hardware. Set the **Program/User** switch on the programming cable back to **User**. Firmly press the **Reset** switch to cycle the power off, and then back on. For the Portable Ground Station, press the power button to cycle the power off, and then back on.

5.2.2 Option 2: Manual Programming

1. From the **Firmware Programmer** options list, select **Firmware Programmer**. This opens the **Firmware Programmer** application.
2. Click the **Browse** button and navigate to the firmware you want to use. In the default software installation, the firmware files are located in the following directories:
 - **Piccolo Firmware:** C: » Program Files » Cloud Cap » Piccolo 2.x » Piccolo.
 - **Ground Station Firmware:** C: » Program Files » Cloud Cap » Piccolo 2.x » Ground Station.
 - **Gimbal Firmware:** C: » Program Files » Cloud Cap » TASE 1.x or 2.x » Gimbal.

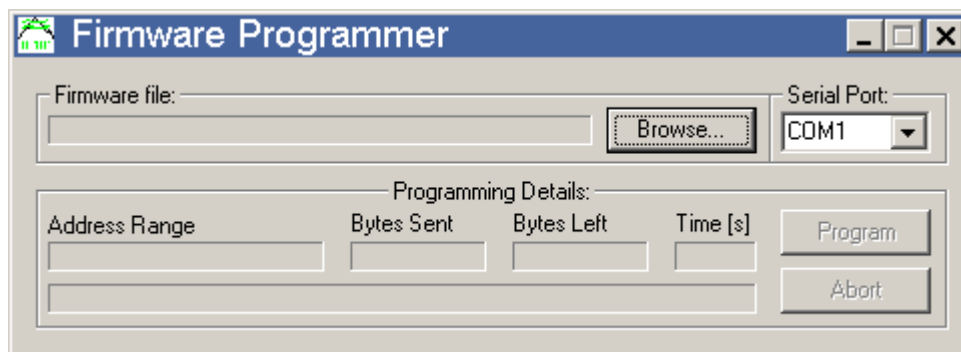

Figure 11 - Firmware Programmer

Note: If you are not using COM1 on the PC to connect to the Piccolo, select the appropriate serial port.

3. Click the **Program** button. You should see the time and details of the programming process display in the window. The program process should take two to three minutes.
4. Reset the Hardware. Set the **Program/User** switch on the programming cable back to **User**. Firmly press the **Reset** switch to cycle the power off, and then back on. For the Portable Ground Station, press the power button to cycle the power off, and then back on.

5.3 Troubleshooting

Problem: A programming error window appears after clicking on the **Program** button in the Firmware Programmer dialog indicating that the hardware device is not responding.

Possible Causes: The most common reason for this error window is failing to cycle the power on and off at the beginning of the programming process or not **FIRMLY** pressing the **Reset** switch to cycle the power. Another common problem is that the hardware device is not receiving power.

Solution: Make sure the hardware device is receiving power. **FIRMLY** press the **Reset** switch to cycle the power on and off where indicated in the programming instructions. If you are still having problems, try manually cycling the power on and off, instead of using the **Reset** switch to cycle the power.



Make sure the programming cable is connected to the correct serial port on your PC.



Figure 12 - Programming Error