

SB 6/30/10 Rev B01 Added length tolerance, cut un-used Glenair wires & encapsulate, specified expando sleeving and shrink tubing types
 SB 9/24/10 Rev C01 ECO 166: Changed encapsulation material for J1
 SB 10/15/10 Rev D01 ECO 194: Changed encapsulation material for J1 & modified dimensional specs, clarified label contents

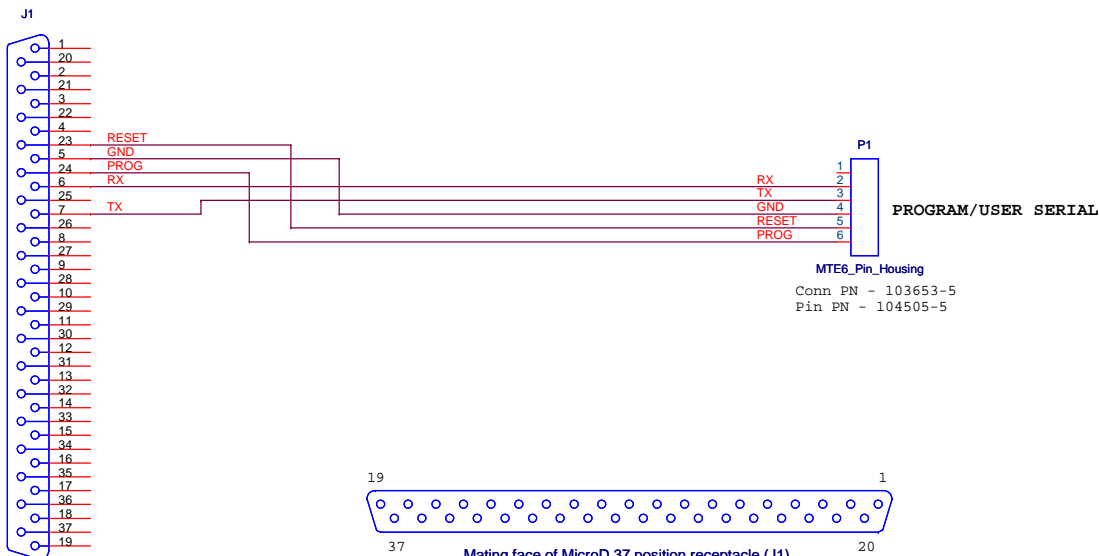

MicroD 37 Position Receptacle, 24 awg pigtailed
 CCT PN 760-01085
 Glenair PN MWD2L-37S-4K1-36B

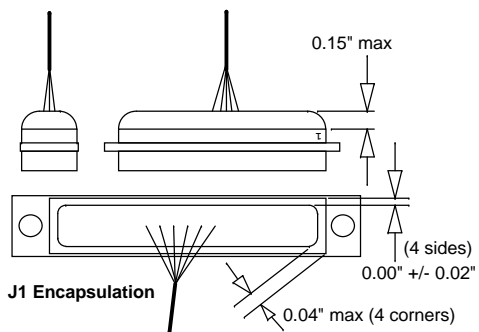
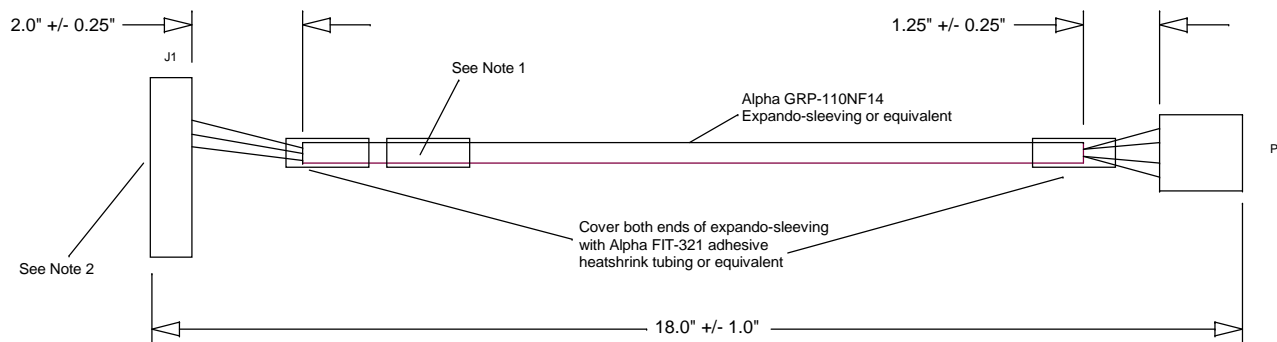

Notes:

- 1) Add Tyco TTMS label over expando-sleeving with the following: "Gimbal Programming Cable" and CCT part number 500-01202-00 REV XXX
- 2) Cut unused wires from J1 flush and encapsulate with 3M Scotchweld DP-100FR White or equivalent. All cut wires must be completely covered by encapsulation. Surface of encapsulation must be smooth; free of flaws/jagged edges.

Cloud Cap Technology Inc		
Title Cable, Gimbal Programming		
Size B	Document Number 500-01202-00	Rev D01
Date: Friday, October 15, 2010	Sheet 1	of 1