

DWG REV.	DATE	DESCRIPTION
A-01	1/7/2009	
ENG-01	1/11/2008	Initial Release

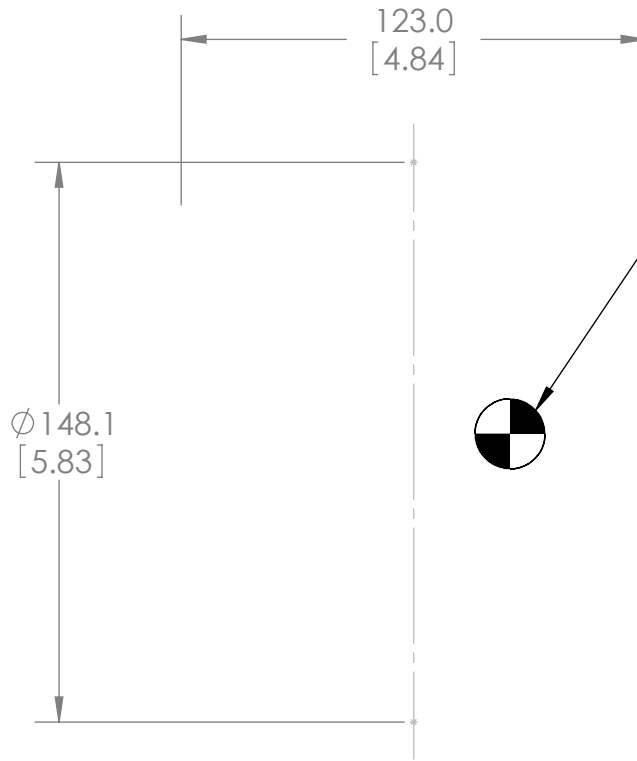

Side Bracket Cutout ∇ 4.0

Note: Side bracket footprint on both sides will depend on specific payload. Additional interior brackets may be needed for payload support

Side Bracket Cutout ∇ 4.0

Payload CG must be located on Tilt section centerline

10.5 ∇ 3
Top and bottom

For 3D geometry, see files:

- T \$ 6 (Payload Volume A-01.prt
- T \$ 6 (Payload Volume A-01.X_T
- T \$ 6 (Payload Volume A-01.STEP

UNLESS OTHERWISE SPECIFIED:
DIMENSIONS ARE IN **MILLIMETERS**
TOLERANCES: ANGULAR = $\pm 0^{\circ}30'$
DECIMAL: X = ± 0.5
.X = ± 0.1
.XX = ± 0.05

PROPRIETARY AND CONFIDENTIAL
THE INFORMATION CONTAINED IN THIS DRAWING IS THE SOLE PROPERTY OF **CLOUD CAP TECHNOLOGY, INC.** ANY REPRODUCTION IN PART OR AS A WHOLE WITHOUT THE WRITTEN PERMISSION OF THE ABOVE IS PROHIBITED.

HOOD RIVER, OR 97031 (541) 387-2120

DRAWN BY: R.Gilchrist 1/11/2008
MATERIAL:
FINISH:

DESCRIPTION:
T \$ 6 (Payload Volume

SIZE B	PART # N/A	PART REV. A-01
WEIGHT:	SCALE: 1:2	SHEET 1 OF 1